

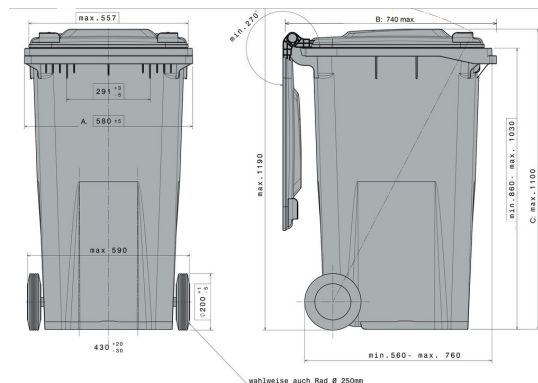

Wheelie bin MGBneo

240 l



Technical data

External Dimensions (mm)	A: 580 ±5	B: 740 max.	C: 1100 max.
Volume (l)	240 l		
Material Body / Material Lid	PE / PE		
Holding Capacity (kg)	96 kg		
Available colours	grey, green, brown, blue, yellow, red		

Characteristics

Characteristics		Extra equipment / Accessories
Container corresponds to:	EN 840, RAL-GZ951/1, Directive 2000/14/EG	Lids openable on both sides
Travelling gear:	External, wheel Ø 200 mm, rubber tired wheels, wheel axle from tempered, galvanized steel	Automatic lock
Receiver:	Comb lift	Reflectors
Prepared for transponder:	Yes	Wheels Ø 250 mm
		Paper aperture
		Glas aperture
		Lid lock

Loading quantities (Pcs / Approximate amount)

On request

Labelling

On the lid, on the body

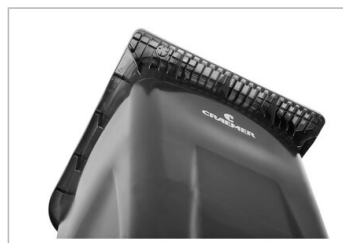

*1 All specifications quoted are subject to change. Craemer reserve the right to make changes to product design and specification.

*2 Extra equipment, accessories, as well as other colors are available at extra cost and on request.