

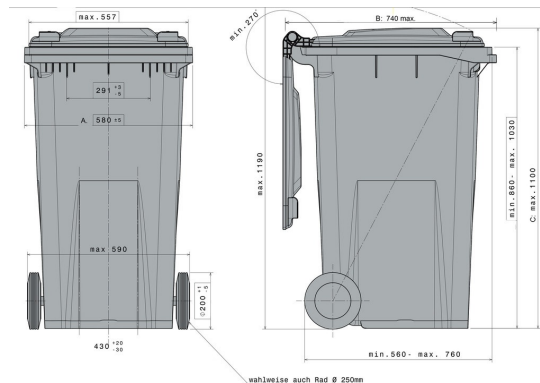



# MGBneo 240 l



## Technical Data\*1

|                                    |  |                             |                               |
|------------------------------------|--|-----------------------------|-------------------------------|
| External Dimensions L x W x H (mm) | <b>Length (mm):</b> 580 ±5   | <b>Width (mm):</b> 740 max. | <b>Height (mm):</b> 1100 max. |
| Volume (l)                         | 240 l  |                             |                               |
| Material Body / Material Lid       | PE / PE  |                             |                               |
| Holding Capacity (kg)              |  96kg |                             |                               |
| Available colours                  | red, green, brown, blue, yellow, anthracite  |                             |                               |

## Characteristics

|                           |   |  |
|---------------------------|---|--|
| Container corresponds to: | EN 840, RAL-GZ951/1, Directive 2000/14/EG   | <b>Extra equipment / Accessories*2</b> |
| Travelling gear:          | External, wheel Ø 200 mm, rubber tired wheels, wheel axle from tempered, galvanized steel | Lids openable on both sides            |
| Receiver:                 | Comb lift   | Lock variants                          |
| Prepared for transponder: | Yes   | Glass aperture                         |
|                           |   | Noise insulation                       |
|                           |   | Labelling clips                        |
|                           |   | Wheel Ø 250 mm                         |
|                           |   | Tilt support                           |

## Loading quantities (Pcs / Approximate amount)

On request

## Labelling

On the lid, on the body



\*1 All specifications quoted are subject to change. Craemer reserve the right to make changes to product design and specification.

\*2 Extra equipment, accessories, as well as other colours are available at extra cost and on request.