

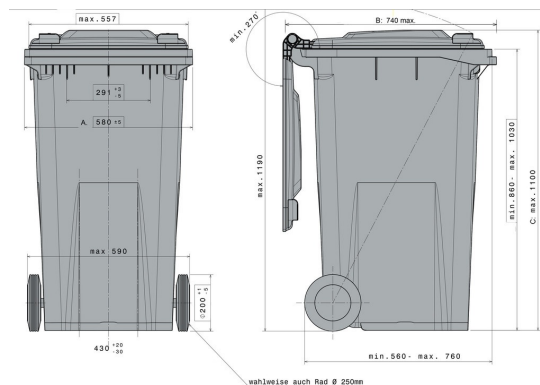

Saloon Lid mit Trennwand 240 | 60 - 40

240 | 60/40



Technical Data*1

External Dimensions L x W x H (mm)	Length (mm): 580 ±5	Width (mm): 740 max.	Height (mm): 1100 max.
Volume (l)	240 l		
Material Body / Material Lid	PE / PE		
Holding Capacity (kg)	 96kg		
Available colours	anthracite		

Characteristics

Container corresponds to: EN840, RAL-GZ 951/1, Directive 2000/14/EG
 External, wheel Ø 250 mm, rubber tired wheels, wheel axle from tempered, galvanized steel
 Travelling gear:
 Receiver: Comb lift
 Prepared for transponder: Yes

Extra equipment / Accessories*2

colour clips for marking the compartments
 noise insulation plugs
 wheels Ø 200 mm
 special colours on request

Loading quantities (Pcs / Approximate amount)

On request

Labelling

On the lid, on the body



*1 All specifications quoted are subject to change. Craemer reserve the right to make changes to product design and specification.

*2 Extra equipment, accessories, as well as other colours are available at extra cost and on request.