

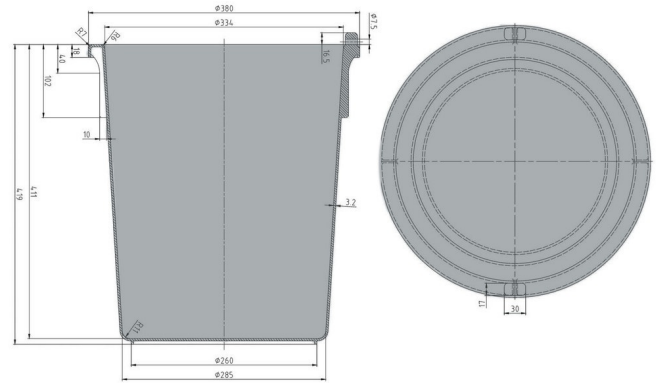

# Bucket

30 l



Art.-Nr.: 90000429

Technical data			
External Dimensions L x W x H (mm)	Ø 380 (o.) x 420		
Internal Dimensions L x W x H (mm)	Ø 330 (top) x 400		
Weight (kg)	1.8 kg		
Volume (l)	30 l		
Material	PE		
Load capacity (kg)	 <b>Holding Capacity</b> 30 kg	 <b>Extra Load</b> -	
Stacking height (mm)	 <b>When nested</b> 105 mm	 <b>When stacked</b> -	
Characteristics		Options	
Colour: black Round, with steel handles Nestable For temperatures ranging from -30 °C to +40 °C, briefly up to +90 °C Resistant to most chemicals and cleaning agents		-	
Loading quantities (Pcs / Approximate amount)			
On request			
Labelling			
Customised printing and numbering available on request depending on quantity. Position upon consultation.			

\*1 All technical data include characteristic features, which have been tested under specially defined conditions. Varying data may result from different conditions of usage such as loading method, prevailing temperature and length of storage time. All data and specified information are subject to change without notice. Our service team is pleased to be at your disposal to check the special requirements of your individual application.