

**The new sturdy container generation for
maximum economy and efficiency.**

MGBplus 120/140/240



KLIKO MGB*plus* – Maximum economy, safety and long life expectancy.

In recent years there have been considerable changes within the private and municipal waste disposal industry. The original waste collection and transport business has been transformed into an environmental management service with a variety of different tasks.

A new generation of sturdy containers.

This change has also brought about new demands on the waste bins. Nowadays the separation of the various waste materials is part of everyday life which leads to higher specific weights and the more frequent use/necessity of a side loading operation. This means that the wastebins are subject to a considerable increase in wear and tear. With the new KLIKO MGB*plus* container Craemer is in a position to meet all the demands of these new developments.

Robust construction.

Due to the special design and the optimal improvement of the parts under the most stress and strain the KLIKO MGB*plus* series offers greater reliability, which means: long-term usage of reliable, resilient and economic bins with no hitches.

The KLIKO MGB*plus* series has been designed with Craemer's philosophy in mind – not just state of the art technology, but always looking for innovative ways to improve KLIKO's top quality products.

Close cooperation with private and municipal waste disposal companies has been the guarantee for creating a new generation of containers designed for the future on which the customer can always count.

This means that as well as the already-proven Diamond system containers, we now have a series of bins for the "comb" lifting mechanism which have been adapted to conform to all the changes in modern waste disposal techniques, and stand up to the constant wear and tear.

Craemer supplies KLIKO MGB*plus* containers in a wide range. You are always economically on the safe side with KLIKO containers, whether they are for residual waste or for collecting recyclable materials.

Long life expectancy.

KLIKO MGB*plus* containers are made of 100 % high quality high density polyethy-

lene. Special features: UV-resistant, long life, free from pollutants such as



cadmium.

Container marking:

Craemer supplies all KLIKO MGB*plus*



containers with individual lid embossing. Additional marking can be applied by hot embossing to suit your personal requirements.

Container lids:

The lid to the MGB*plus* has been reconstructed and adapted to fit the design of the body.

Craemer can also supply the KLIKO MGB*plus* bins with special lids for glass- or paper-collection on request.

Special construction for code chips:

- All versions suitable for retrospective fitting
- Further extras on request.



Container recycling

KLIKO containers can be recycled by means of regranulation and the recovered granules can be used to manufacture a variety of products, thus forming a complete circle.

Technical features:

- Volumes:120l up to 240l
- MGB in acc.with EN 840
- resistant to chemical and biological effects
- smooth surfaces prevent refuse from sticking. Almost no residue left in the bin after emptying.
- rubber tyred wheels for easy handling
- all-round handle
- available in all colours or colour-combinations (in/lid)
- prepared fitting for code-chip
- special front shaping
- reinforced axle-mounting

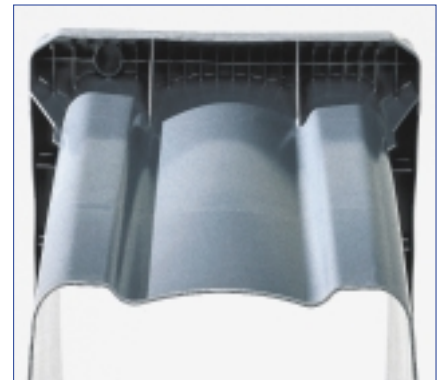

Practical results:

- Costs are minimised as it is hardly ever necessary to replace faulty bins
- optimum preparation for the use of newer and faster loading techniques.



Technical Features.

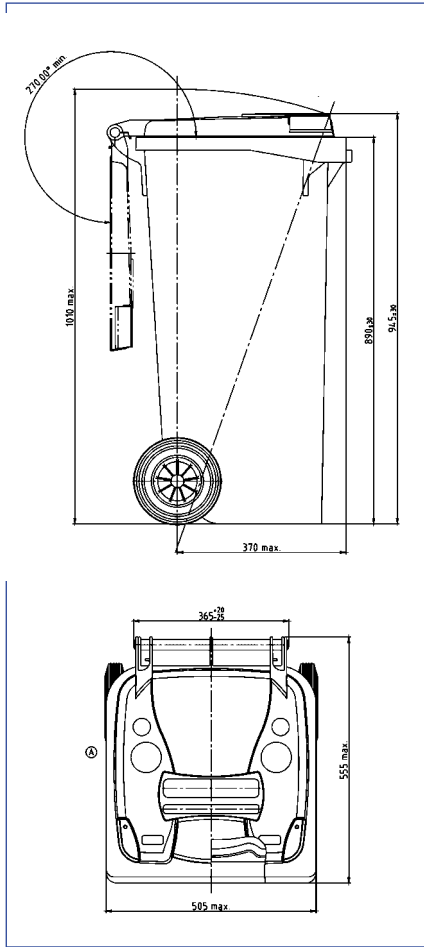

MGBplus 120 1

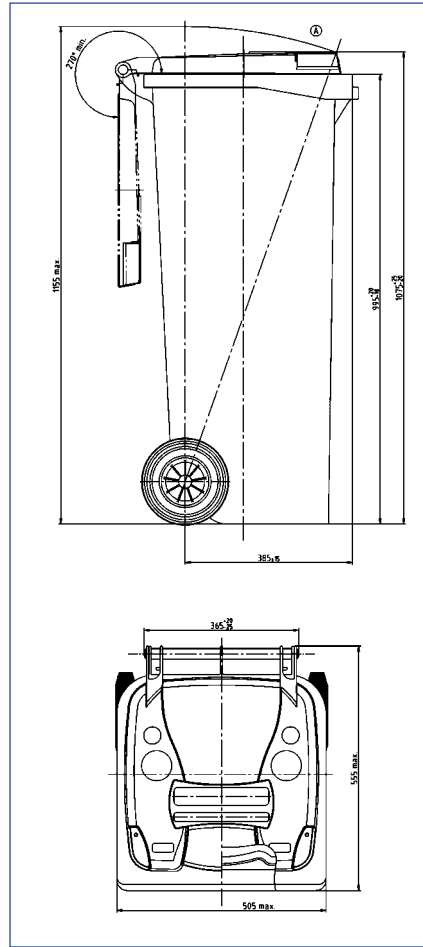

MGBplus 140 1

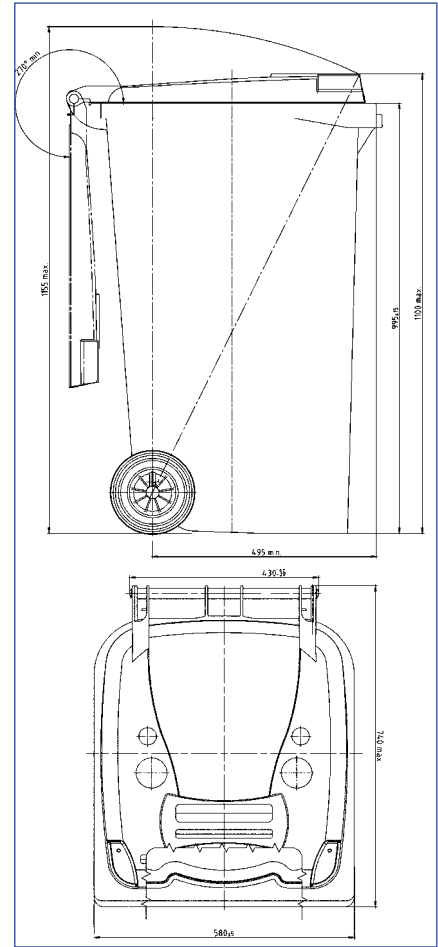

MGBplus 240 1

